

THIS DRAWING IS UNPUBLISHED. RELEASED FOR PUBLICATION  
 © COPYRIGHT - By - ALL RIGHTS RESERVED.

LOC	DIST	REVISIONS			
P	LTR	DESCRIPTION	DATE	DWN	APVD
FT	64	A1	REVISED PER ECO-11-004835	11MAR11	RK HMR

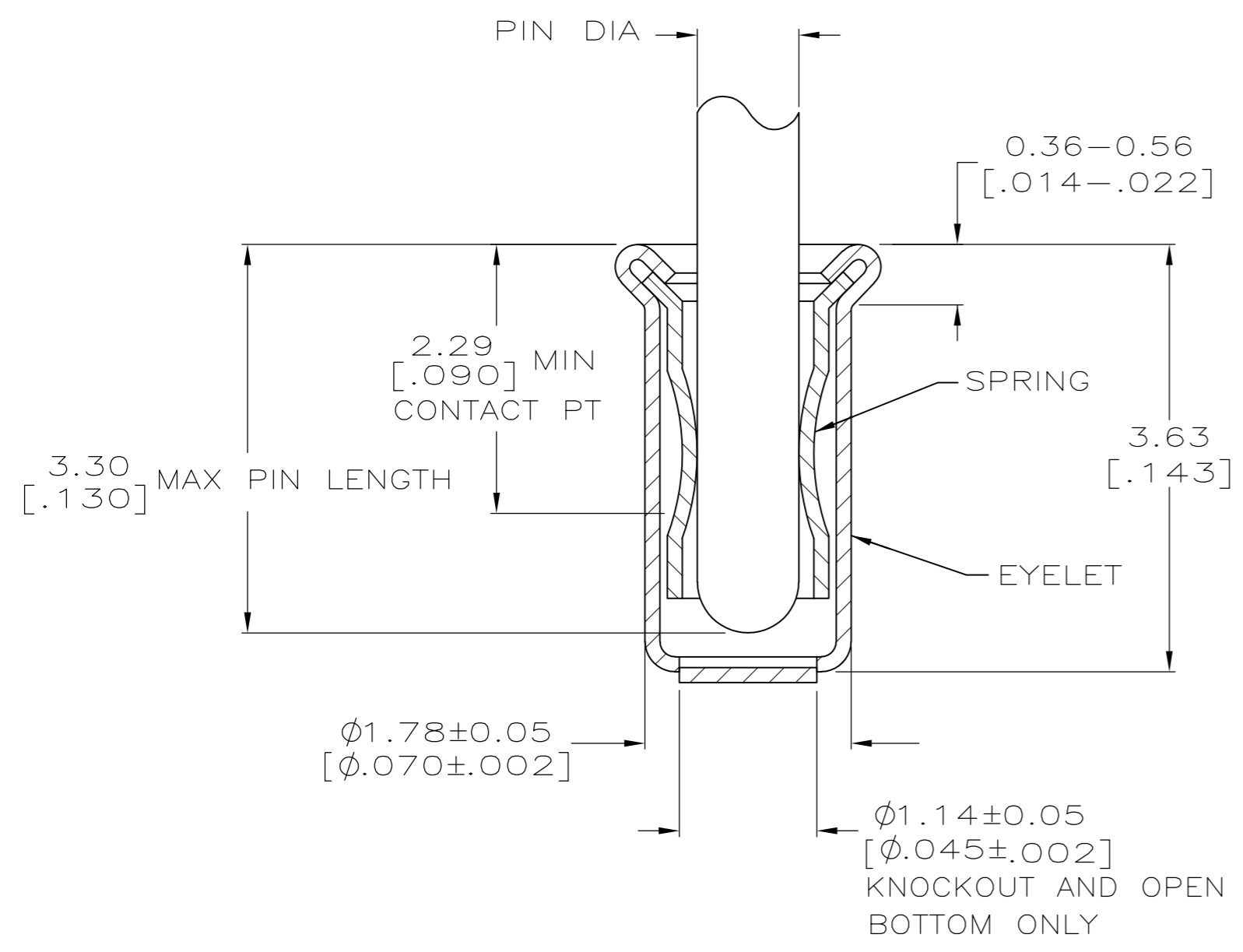
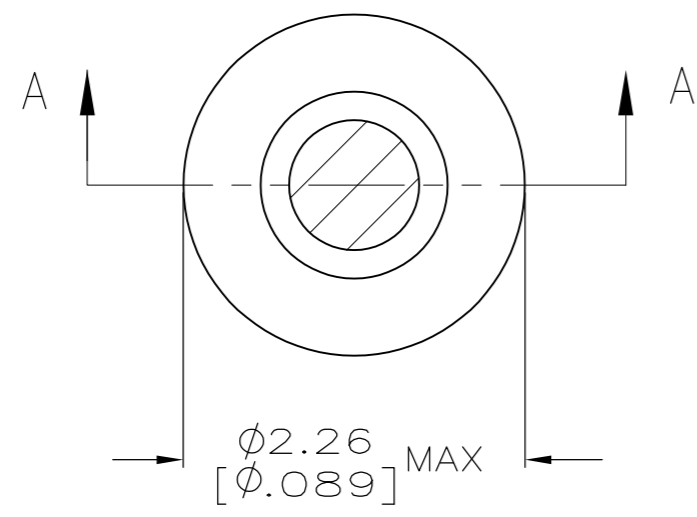

SECTION A-A

- 1. TIN PLATE PER ASTM B 545 0.00254 [.000100] MIN THICK.
- 2. NICKEL UNDERPLATE ALL OVER, MATING SURFACE PLATED TO MEET PERFORMANCE REQUIREMENTS OF TE CONNECTIVITY PRODUCT SPECIFICATION 108-14008.
- 3. RECOMMENDED HOLE SIZE, PLATED OR UNPLATED:
  - MACHINE INSERTION:  $1.83 \begin{matrix} +0.10 \\ -0.08 \end{matrix} \begin{matrix} [.072 +.004 \\ -.003] \end{matrix}$
  - HAND INSERTION:  $1.83 \begin{matrix} +0.10 \\ -0.00 \end{matrix} \begin{matrix} [.072 +.004 \\ -.000] \end{matrix}$
- 4. APPLICATION TOOL PART NUMBER: MACHINE NO. 682127-5  
INSERTION HEAD NO. 682039-4
- 5. TO INSURE PROPER SPRING TENSION DO NOT EXCEED A 0.05 [.002] DIFFERENCE IN PIN DIA WHEN CHANGING TO A SMALLER PIN.
- 6. BOTTOM PLUG KNOCKOUT TOOL PART NUMBER 69729 WITH TIP PART NUMBER 69728-2.
- 7. MATERIAL:  
SPRING: BERYLLIUM COPPER PER ASTM B 194  
EYELET: COPPER PER ASTM B 152

OBSOLETE

OPEN	0.71-0.84 [.028-.033]	TIN	1	GOLD 2	4-5332070-4
KNOCKOUT	0.94-1.02 [.037-.040]			TIN 1	3-5332070-5
OPEN	0.94-1.02 [.037-.040]	TIN	1	GOLD 2	2-5332070-9
	0.86-0.94 [.034-.037]			TIN 1	2-5332070-8
	0.76-0.84 [.030-.033]			GOLD 2	2-5332070-6
CLOSED	0.94-1.02 [.037-.040]	TIN	1	GOLD 2	2-5332070-5
	0.86-0.94 [.034-.037]			TIN 1	2-5332070-3
BOTTOM TYPE	RECOMMENDED PIN DIA	EYELET	5	GOLD 2	2-5332070-2
				SPRING	GOLD 2
				FINISH	PART NO

THIS DRAWING IS A CONTROLLED DOCUMENT.		DWN	22APR2005	A. FERNANDEZ-DOCK5	
DIMENSIONS: INCHES		CHK	22APR2005	J. HAVENER	
TOLERANCES UNLESS OTHERWISE SPECIFIED:		APVD	22APR2005	J. HAVENER	
0 PLC	± -	NAME			
1 PLC	± -	PRODUCT SPEC			
2 PLC	± -	108-14008			
3 PLC	± 0.20 [.008]	APPLICATION SPEC			
4 PLC	± -	114-13152			
ANGLES	± -	WEIGHT			
MATERIAL	1	-			
FINISH		SEE TABLE			
CUSTOMER DRAWING		SCALE	20:1	SHEET	1 of 1
		REV	A1		